

2016 FRAME MANUAL

PATROL

Transition



Congratulations on the purchase of your Transition frame. This manual will give you helpful information on how to develop a long and lasting relationship with your bike.

FRAME SPECS

REAR TRAVEL:	155mm (6.1")
FRONT TRAVEL:	160mm (6.3")
REAR SHOCK:	216mm x 63mm (8.5" x 2.5") (21.8mm x 8mm eyelets)
FRAME MATERIAL:	6061 Aluminium
SIZES:	Small, Medium, Large, XL
COLORS:	Highlighter Yellow, Satin Black
MatteWARRANTY:	2 year defect warranty Lifetime crash replacement

BUILD SPECS

SEATPOST/CLAMP:	31.6mm Seatpost/34.9mm Clamp
HEADTUBE:	44mm/56mm Zero Stack
BOTTOM BRACKET:	73mm English Threaded
REAR DROPOUT:	142 x 12mm
FRONT DERAILLEUR:	SRAM S3 LDM/Shimano E2
CHAINGUIDE:	ISCG 05
REAR BRAKE:	160mm IS
REAR AXLE:	Syntace X12 12mm x 142mm
WHEEL SIZE:	27.5"

SHOCK SETUP

Your Transition frame is fully equipped with GiddyUp suspension technology. The custom tuned rear shock is designed to work perfectly in conjunction with the frame's leverage curve to provide superb pedaling performance and downhill small and big bump sensitivity. As a starting point all GiddyUp bikes are recommended to have 33-35% sag. Adjustments like rebound and compression are all personal preference settings that should be adjusted to your personal riding style and preferences. Consult your shock manual for information about how to adjust your rear shock.

MAINTENANCE & INSPECTION

It is crucial to the longevity of your Transition frame that you properly maintain and inspect it. We recommend that all service be done by a qualified Transition Bikes dealer.

Before you begin any ride it is very important to inspect your entire frame for any cracks, loose pivots or bolts, and properly functioning bearings. In addition to inspecting your frame, checking your entire bike to make sure it is working properly must happen before every ride. This includes but is not limited to checking tire pressure, ensuring the wheels are secure to the frame and fork, all components and brake bolts are tight and pedals are secure. Also, a quick check of your brake pads and brakes to insure they are working properly and ready to ride. If you are unsure of what you need to check on your bike to make sure it is safe, please bring your bike to a bicycle shop to have them inspect and maintain it before you begin a ride.

TORQUE SETTINGS

Proper torque ratings for the hardware used on this product are crucial to keeping your frame working in proper order and preventing damage to the frame and pivots during use. Damage caused by over/under torquing will not be covered by the warranty on this product. All torque settings can be found on the exploded frame view on page 3 of this document.

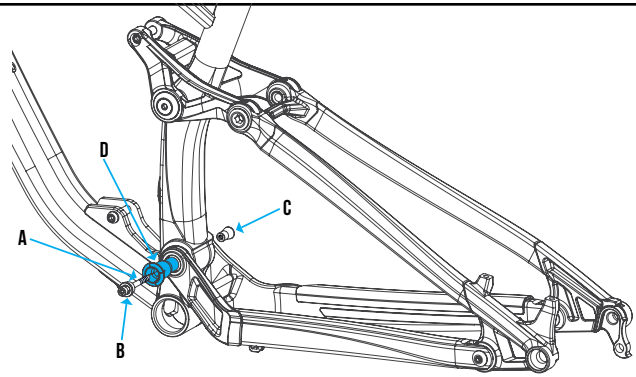

MAIN PIVOT

The main bottom bracket pivot on your GiddyUp family bike is equipped with a collet style hardware system. This type of pivot requires a two step process to tighten correctly. Step 1. removed the main pivot screw (A) with a 4mm hex wrench, then slide out main pivot taper nut (B). Please note that the threaded main pivot taper nut (C) may slide out as well but is not necessary to remove. Step 2. With an 8mm hex wrench tighten the main pivot axle (D) clockwise until you reach the specified torque of 19nm. Next, make sure both main pivot taper nuts are in position and reinstall the main pivot screw to the specified torque of 7nm. The pressure from the main pivot screw and taper nuts will help to maintain correct torque on the main pivot axle and increases the rear end stiffness of your frame.

BEARINGS

Take apart all the linkage and rocker arms to inspect the bearings to see if they are rotating smoothly. If they do not feel smooth or are seized up, you should replace the affected bearings. Always replace bearings in pairs.

Bottom Bracket Main Pivot Bearings Qty: 2 - 6903-2RS
Main Rocker Arm Pivot Bearings Qty: 2 - 6902-2RS
Seatstay and Chainstay Pivot Bearings Qty: 4 - 3802-2RS

WARRANTY

Your Transition frame comes with a 2 year manufacturing defect warranty and a lifetime crash replacement policy. This warranty does not cover normal wear and tear to the frame, crashes, miscalculated landings and running into stuff. All those things would be covered by the crash replacement policy. If something bad occurs to your frame that is not covered by the warranty Transition will provide a replacement frame at a killer deal. Our goal is to make sure everyone can keep riding and has a smile on their face.

To be eligible for a warranty you must be the original owner and you must register your frame on the Transition Bikes website under the "Support" button.

For more technical support and information, visit our website and click on the "Support" button or contact us directly at:

Transition Bikes / 1600 Carolina St. /Bellingham, WA 98226
info@transitionbikes.com / (360) 366-4960 / www.transitionbikes.com

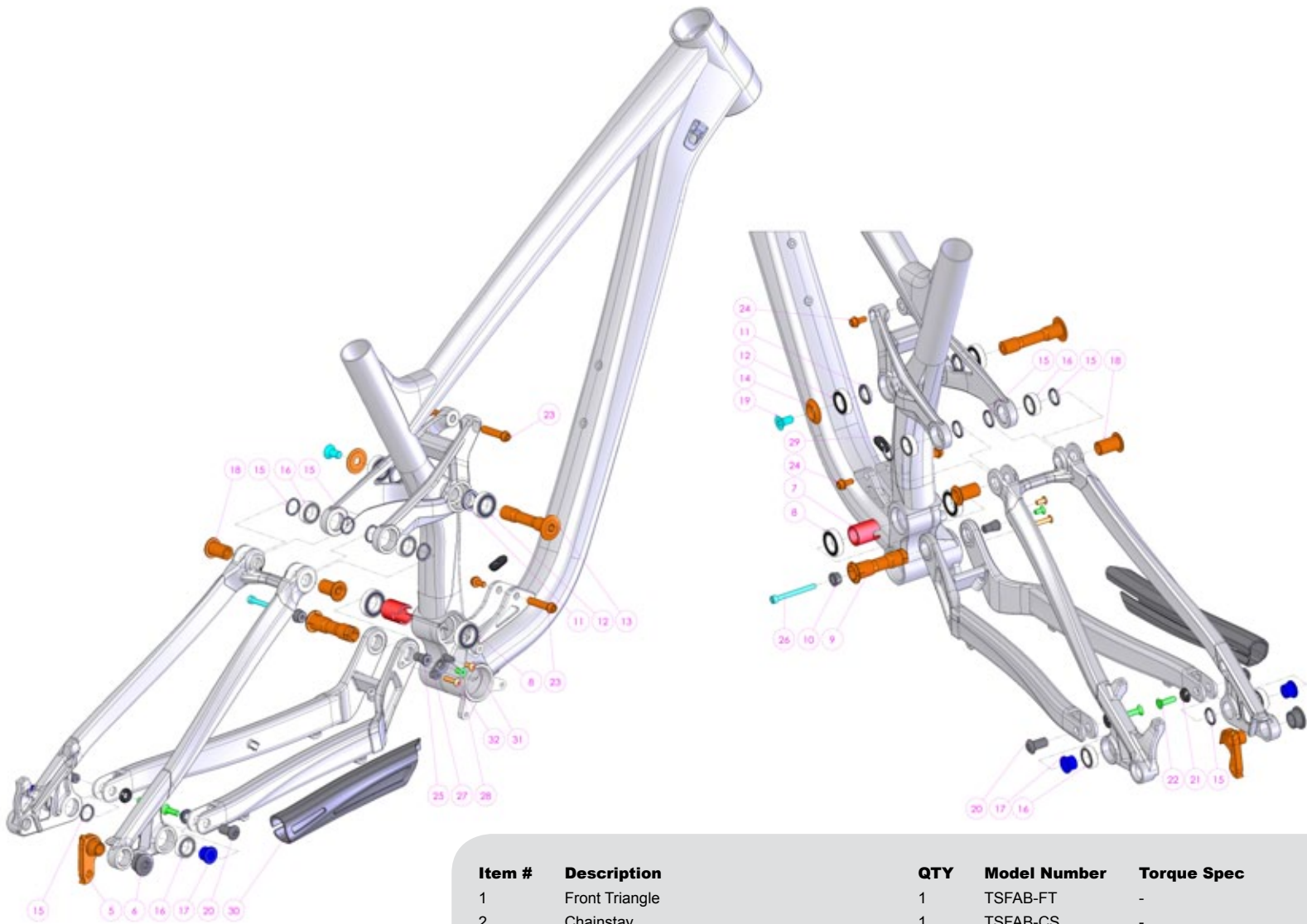

Item #	Description	QTY	Model Number	Torque Spec
1	Front Triangle	1	TSFAB-FT	-
2	Chainstay	1	TSFAB-CS	-
3	Seatstay	1	TSFAB-SS	-
4	Rocker Link	1	TSFAB-LK	-
5	Derailleur Hanger	1	TSFA-HG	-
6	Derailleur Hanger Retention Bolt	1	C7A-ANT	19nm
7	Main Pivot Spacer (17mm x 28mm)	1	TSFA-BSP	-
8	Bearing (30mm x 17mm x 7mm)	2	6903-2RS	-
9	Main Pivot Axle (17mm x 66.5mm)	1	TSFA-MAX	19nm
10	Main Pivot Taper Nut	1	TSFA-MNT	-
11	Bearing Spacer (22mm x 15mm x 3mm)	2	TEDC-BWS	-
12	Bearing (28mm x 15mm x 7mm)	2	6902-2RS	-
13	Rocker Pivot Axle (17mm x 76mm)	1	TSFA-LAX	-
14	Rocker Pivot Axle Cap	1	TSFA-LNT	-
15	Bearing Spacer (19mm x 15mm x 2.5mm)	6	TSFA-LWS	-
16	Bearing (24mm x 15mm x 7mm)	4	3802-2RS	-
17	Chainstay Pivot Reducer	2	TSFA-EAX	-
18	Seatstay Pivot Axle (15mm x 22.5mm)	2	TSFA-SAX	19nm
19	Rocker Pivot Screw	1	M8 x 16L-M	10nm
20	Chainstay Pivot Axle (10mm x 22.5mm)	2	TSFA-CAX	-
21	Chainstay Pivot Axle Cap	2	C65A-RCP	-
22	Chainstay Pivot Screw	2	M6 x 20L-M	7nm
23	Shock Bolt	2	TCVC-BT-34L-S	10nm
24	Shock Screw	2	TCVC-M6-S	10nm
25	Main Pivot Taper Nut (Threaded)	1	TSFA-MNT-R	-
26	Main Pivot Screw	1	M5 x 50L-P	7nm
27	Front Derailleur Mounting Bracket	1	TSFA-FDM	-
28	Front Derailleur Mounting Bracket Screw	1	M5 x 10L-M	3nm
29	Cable Grommet	1	TCBC-CGR	-
30	Chainstay Protector	1	TSFA-CPT	-
31	Front Derailleur Attachment Screw	1	M5 x 10L-R-S	3nm
32	Front Derailleur Attachment Screw	1	M5 x 20L-R-S	3nm



GEOMETRY

	SM	MD	LG	XL
Reach	406	432	457	483
Stack	591	600	609	618
Effective TopTube	555	583	613	641
SeatTube	393	419	457	495
SeatTube Angle	76	75.4	74.9	74.5
HeadTube Length	100	110	120	130
HeadTube Angle	65	65	65	65
Chainstay	430	430	430	430
Wheelbase	1151	1181	1210	1240
BB Drop	15	15	15	15
Estimated BB Height	339	339	339	339
Standover Height	685	693	705	717